

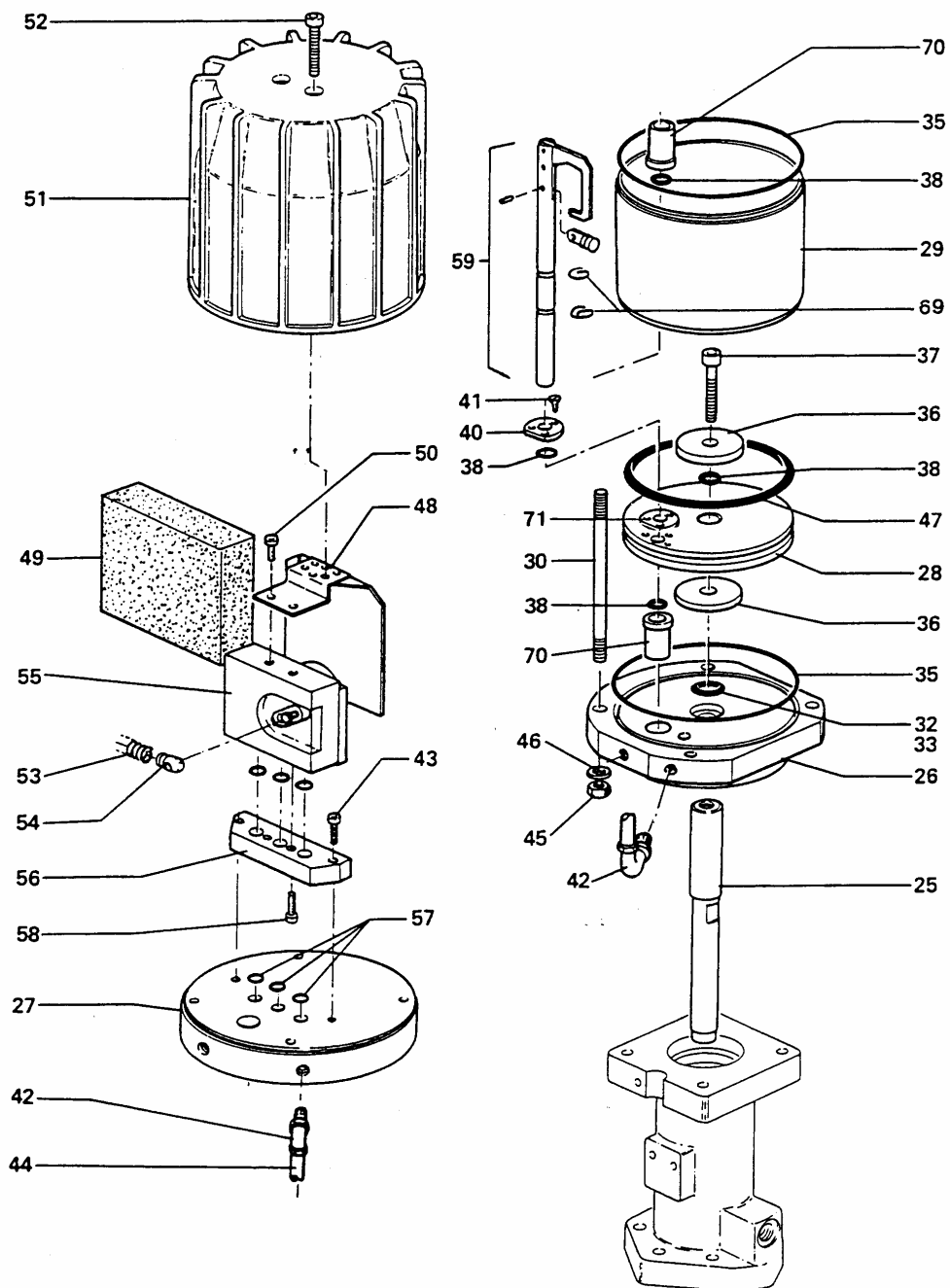

Doc. 573.005.050 Date/Datum/Fecha : 01/06/02 Annule/Cancel/ Ersetzt/Anula :	Modif. /Änderung :	Pièces de rechange Spare parts list Ersatzteilliste Piezas de repuesto
---	---------------------------	---

MOTEUR A AIR, modèle 1000-2	AIR MOTOR, model 1000-2	#
LUFTMOTOR, Modell 1000-2	MOTOR DE AIRE, tipo 1000-2	144.910.200



MOTEUR A AIR, modèle 1000-2
LUFTMOTOR, Modell 1000-2

AIR MOTOR, model 1000-2
MOTOR DE AIRE, tipo 1000-2

144.910.200

Ind	#	Désignation	Description	Bezeichnung	Denominación	Qté
25	044.910.012	Tige moteur	Rod, air motor	Steuerstange	Tirante, motor	1
26	044.910.208	Fond inférieur	Lower flange	Unterer Flansch	Fondo inferior	1
27	044.910.209	Fond supérieur	Upper flange	Oberer Flansch	Fondo superior	1
*28	044.910.203	Piston moteur	Piston, air motor	Motorkolben	Pistón motor	1
*29	044.910.207	Cylindre	Cylinder	Zylinder	Cilindro	1
30	044.910.017	Tirant moteur	Tie-rod, air motor	Verbindungsbolzen	Tirante motor	4
32	144.585.354	Joint Ø 23 (pochette de 10)	Seal Ø 23 / 29/32" (package of 10)	O-Ring Ø 23 (10er Pack)	Junta Ø 23 (bolsa de 10)	1
33	044.720.016	Bague d'étanchéité	Ring	Dichtring	Anillo de estanquidad	1
35	100.940.470	Joint (pochette de 10)	Seal (package of 10)	O-Ring (10er Pack)	Junta (bolsa de 10)	2
36	044.890.107	Butée de piston	Piston thrust	Kolbenanschlag	Tope de pistón	2
37	930.151.502	Vis CHc M 10 x 40	Screw, CHc M 10 x 40	Schraube, CHc M 10 x 40	Tornillo CHc M 10 x 40	1
38	144.579.923	Joint R8 bis (pochette de 10)	Seal R8 bis (package of 10)	O-Ring R8 bis (10er Pack)	Junta R8 bis (bolsa de 10)	4
40	044.910.204	Palier	Bearing	Ring	Palier	1
41	932.221.166	Vis Hc F90° - M 4 x 12	Screw, Hc F90°-M 4 x 12	Schraube, HcF90°-M4x12	Tornillo Hc F90° - M 4 x12	3
42	905.150.012	Raccord coudé M 1/4 – T 8 x 12	Elbow connector, 1/4 -T 8 x 12	Winkelniessel M 1/4 – T 8 x 12	Racor acodado M 1/4 - T 8 x 12	3
43	930.151.446	Vis CHc M 8 x 35	Screw, CHc M 8 x 35	Schraube, CHc M 8 x 35	Tornillo CHc M 8 x 35	2
44	539.310.101	Tuyau noir T 8 x 12 (lg. 0,45 m)	Hose (black) T 8 x 12 (lg. 0,45 m / 18")	Schlauch (schwarz) T 8 x 12 (L : 0,45m)	Tubería (negra) T 8 x 12 (0,45 m de largo)	1
45	953.010.019	Ecrou HM 8	Nut, HM 8	Mutter HM 8	Tuerca HM 8	4
46	963.040.019	Rondelle MN 8	Washer, MN 8	Scheibe MN 8	Arandela MN 8	4
47	909.130.451	Bague R 49	Ring, R 49	O-Ring R 49	Anillo R 49	1
48	044.910.205	Support silencieux	Support, silencer	Schalldämpfer-Halterung	Soporte silenciador	1
49	044.910.206	Silencieux mousse	Silencer	Schalldämpfer aus Schaumstoff	Silenciador	1
50	933.011.170	Vis HM 6 x 12	Screw, HM 6 x 12	Schraube, HM 6 x 12	Tornillo HM 6 x 12	2
51	044.570.135	Cloche	Cover	Glocke	Campana	1
52	933.151.387	Vis CHc M 6 x 30	Screw, CHc M 6 x 30	Schraube, CHc M 6 x 30	Tornillo CHc M 6 x 30	2
53	050.311.232	Ressort inverseur	Spring, reversing block	Umschaltfeder	Muelle inversor	1
54	044.570.131	Chape femelle	Linkage female	Verbindungsflansch	Chapa hembra	1

Ind	#	Désignation	Description	Bezeichnung	Denominación	Qté
*55	044.630.400	Ensemble bloc inverseur (voir doc. 573.087.040)	Reversing block assembly (refer to doc. 573.087.040)	Umschaltblock (siehe Dok. 573.087.040)	Conjunto bloque inversor (consultar doc. 573.087.040)	1
56	046.230.005	Embase	Base	Basis	Base	1
57	909.420.257	Bague O Ring	O Ring	O-Ring	Anillo O Ring	3
58	932.151.277	Vis CHc M 6 x 20	Screw, CHc M 6 x 20	Schraube CHc M 6 x 20	Tornillo CHc M 6 x 20	2
59	044.910.250	Fourchette de commande équipée	Control fork assembly	Steuergabel	Horquilla de mando equipada	1
69	902.202.110	Truarc	Circlips	Sicherungsring	Truarc	2
70	044.650.018	Bague de guidage	Guide ring	Führungsring	Anillo de dirección	2
71	044.910.210	Joint palier	Seal, bearing	Dichtring	Junta palier	1
-	901.180.024	Câble de mise à la terre (Lg. 5 m)	Ground (Length 5 m / 196.85")	Erdungskabel (L. 5 m)	Cable de puesta a tierra (5 m de largo)	1
-	963.300.016	Rondelle	Washer	Scheibe	Arandela	1
-	934.011.196	Vis H 6 x 16	Screw, H 6 x 16	Schraube H 6 x 16	Tornillo H 6 x 16	1

*	144.919.904	Pochette de joints (ind. 32, 33, 35, 38, 47, 53, 57, 71 + pochette de joints du bloc inverseur)	Package of seals (ind. 32, 33, 35, 38, 47, 53, 57, 71 + package of seals of the reversing block)	Dichtungskit (Pos. 32, 33, 35, 38, 47, 53, 57, 71 + Dichtungssatz für Umschaltblock)	Bolsa de juntas (ind. 32, 33, 35, 38, 47, 53, 57, 71 + bolsa de juntas del bloque inversor)	1
*	144.919.914	Pochette de maintenance (ind. 69, 70 + pochette de joints moteur + ind. 3, 5, 7, 8, 13 de l'inverseur)	Servicing kit (ind. 69, 70 + package of seals of the air motor + ind. 3, 5, 7, 8, 13 of the reversing block)	Servicekit (Pos. 69, 70 + Dichtungssatz für Motor + Pos. 3, 5, 7, 8, 13 für Umschaltungsblock)	Bolsa de mantenimiento (ind. 69, 70 + bolsa de juntas motor + ind. 3, 5, 7, 8, 13 del inversor)	1

- * Pièces de maintenance préconisées tenues en stock
- * Preceding the index number denotes a suggested spare part.
- * Bezeichnete Teile sind empfohlene Ersatzteile.
- * Piezas de mantenimiento preventivo a tener en stock.